

Building Maintenance Unit – PC400 hoist

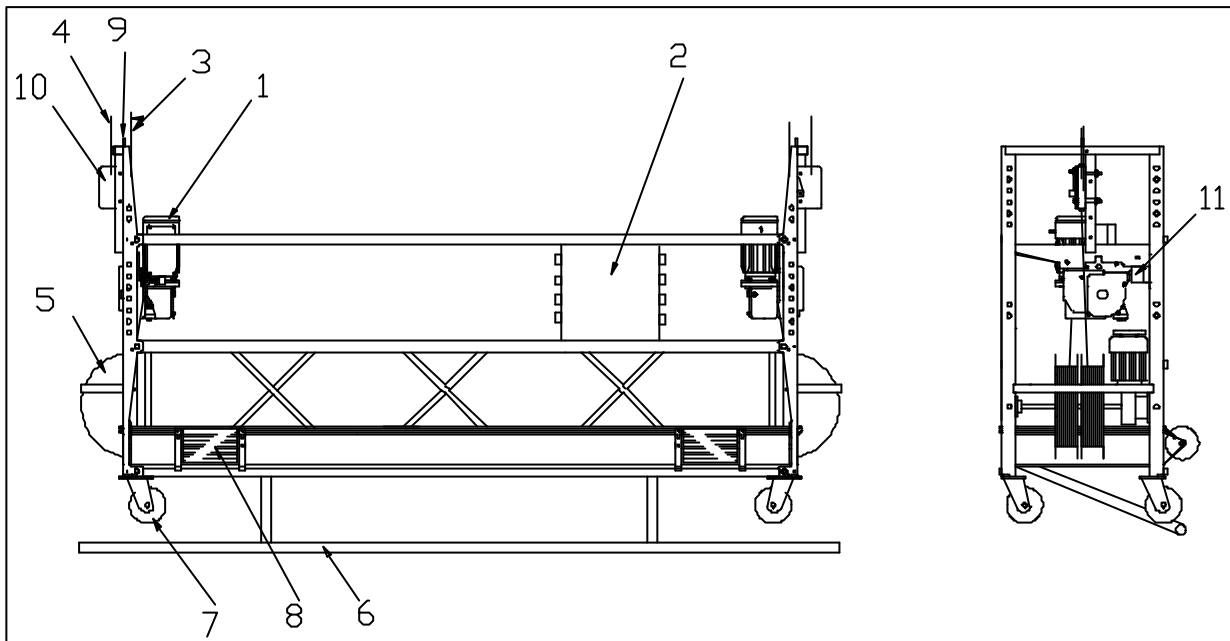

Standard features

- Lightweight aluminium construction
- Powered by PC400 hoist with thermal protection (1)
- Power supply: 3x415V+Neutral +Earth, three phase, 50Hz
- Slack rope safety device (9)
- Top limit switch in series (10)
- Bottom limit trip bar (6)
- Electro-mechanical overload detection device in series (11)
- Electro-mechanical service brake
- 'No Power' emergency descent system
- Twin-drum wire winders up to 100m (5)
- Toeboard protection for wire winder
- External protection bar for wire winder
- Low-noise castor wheels Ø160mm (7)
- Non-marking soft wall rollers (8)
- Safety harness attachment points
- Climbing speed: 8.0 m/min.
- Safety rope (4) and suspension rope (3): Ø 8.4 mm (52.3 kN)

Central Control Box (2)

- Hold to run 'up/down' operating buttons
- Emergency stop
- Hoist selector switch (left/both/right)
- 230V control circuit
- Overload warning light
- Bottom trip bar bypass button
- 'Power On' indicator light
- Thermal protection for wire winder motors
- Phase protector
- Phase reversing power plug

Optional

- Telescopic wall rollers
- Cable bin
- Other power supplies on special request

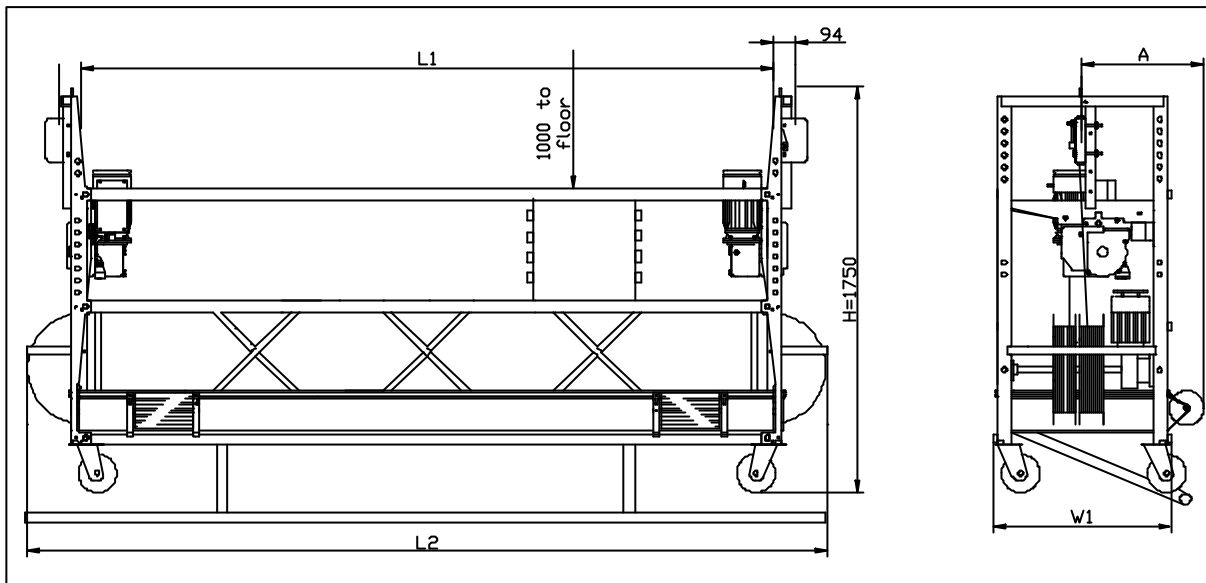

Width over guardrail	700 mm
A = Distance suspension wire to façade	510 mm
W1 = Nominal width	743 mm

PLATFORM TYPE	2 m	3 m
L1 = Suspension rope centres	1985 mm	2902 mm
L2 = Nominal length (mm)	2000 mm	3000 mm
Self-weight (See note 1)	300 kg	350 kg
Safe Working Load (SWL)	2500 N	2500 N

- (1) Self-weight without steel wire rope and power supply cable.
Add 1.35 kg/m for steel wire rope and power supply cable.

Ref.: 38206-01	Issue Date: 10-okt-2003
POWER CLIMBER bvba Tel: +32-3-451.05.00 Fax: +32-3-451.05.01 E-mail: Info@PowerClimber.be	POWER CLIMBER ASIA Ltd Tel: 852-2310.2855 Fax: 852-2745.0755 E-mail: Infopcal@powerclimber.com.hk
Website: www.PowerClimber.be	

*This document and all copies are property of Power Climber bvba. All dimensions and data are indicative only.
The user must ensure that the equipment complies with local rules and regulations.*